

SUTHERLANDSHIRE

B7 BUSINESS PARK

DCP 2015 CHAPTER 27



Contents

1.	Subdivision	2
2.	Streetscape and Building Form	3
3.	Building Setbacks	6
4.	Daylight Access	8
5.	Acoustic Privacy.....	9
6.	Landscaping	10
7.	Access	15
8.	Safety and Security	16
9.	Parking	17
10.	Late Night Trading Premises.....	20
11.	Waste from Industrial, Commercial and Educational Establishments	21

This part of the DCP provides development standards for development in Zone B7 Business Park

It should be read in conjunction with Vehicular Traffic Parking and Bicycles (Ch.36), Stormwater and Groundwater Management (Ch.38), Part 1 Natural Resource Management (Ch.39), Environmental Risk (Ch.40), Social Impact and Administrative Provisions (Ch.42). Depending on the proposed use, Chapter 37 - Late Night Trading may also apply.

Council's Public Domain Manual contains guidelines for public domain design, for example street furniture and footpath design and materials.

B7 Business Park is a zone which allows office premises as well as general industrial uses. This use of the zone is a response to the changing nature of manufacturing, industry and business services in NSW, and is intended to optimise the future employment-generating potential of underutilised industrial areas.

In common with other business zones, B7 is an 'open zone' under the LEP, which means that prohibited uses are listed and all other uses are permissible. The benefits of this method is that new uses not yet included in the LEP dictionary definitions will be permissible, provided they are consistent with the objectives of the zone.

Parts of Taren Point employment area have been zoned B7 Business Park. The zone has been allocated to encourage the retention of large sites in these locations. It is intended that redevelopment of these sites will maintain or establish high quality landscaping including large trees, contributing to the creation of an attractive streetscape and good amenity on the sites. An attractive well landscaped area should attract more businesses to establish in the area.

The Taren Point employment area is located in close proximity to an environmentally sensitive waterway. The strategy seeks to minimise the environmental impacts of industrial development. It also aims to improve the visual and environmental performance of the precinct through the reinstatement of indigenous canopy trees.

1. Subdivision

The size and shape of a land parcel influences the relationship of a new building to its neighbours.

Subdivision patterns and site amalgamation can have significant implications for the streetscape of an area. Effective amalgamation patterns promote the efficient use of land and allow design constraints to be more easily resolved. In particular, they help to produce a consistent urban form and built form 'rhythm' that reflect the surrounding development pattern. They also attempt to balance planning requirements relating to height, massing, underground car-parking, vehicular access, streetscape and amenity to achieve appropriate building outcomes.

1.1 Objectives

1. Retain large sites to accommodate large scale businesses.
2. Ensure sites are large enough to achieve appropriate streetscape presentation with adequate vehicle access, vehicle manoeuvrability and onsite parking.

1.2 Controls

1. The minimum gross floor area of each unit is 150m² for a warehouse/factory unit within a strata subdivision effected under the Strata Schemes (Freehold Development) Act 1973.

2. Streetscape and Building Form

Good design provides a building layout that maximises the natural attributes of the site. Carefully considered building layout and design also creates a higher level of amenity for occupants through passive heating and cooling and attractive outlooks.

Streetscape is the urban environment created by the relationship of built elements to the public domain. The quality and scale of architecture, landscape elements, natural elements and works in the public domain determine the streetscape character.

Facades are the external face of buildings and make an important contribution to the streetscape. The pattern or rhythm established by the proportions of the facade, the modulation of the external walls, the design of façade elements, their materials and detailing are all important considerations. Architectural quality contributes to the character and quality of the streetscape. High architectural quality requires appropriate composition of building elements, textures, materials and colours and reflects the use, internal layout and structure of a development.

2.1 Objectives

1. Ensure that elements of development visible from the street, waterways and public domain make a positive contribution to the locality.
2. Achieve quality architecture in new development through the appropriate composition and articulation of building elements, textures, materials and colours that respond to the building's use.
3. Create entrances and site layouts which provide a desirable and safe identity for the development and which assist in visitor orientation.
4. Achieve high quality working environments.
5. Ensure development incorporates passive solar design principles, energy efficiency, water conservation and opportunities for natural ventilation.
6. Improve the visual amenity of the public domain.

2.2 Controls

1. Facades are to be composed with an appropriate scale, rhythm and proportion responding to the building's context and use.
2. Where visible from the street, the façade should be articulated. Where blank walls are unavoidable, landscape screen planting is to be utilised to reduce visual impact of the building when viewed from the public domain or residential development.

Note to Subclause 2:

Articulation can be provided by building setbacks, building structural elements, balconies, balustrades, cladding, sun shading devices and awnings, porticos, blade walls or projecting bays, and roofing and drainage elements. Large flat facades are to be avoided.

3. Building entrances are to be clearly defined and located so that visitors can readily distinguish the public entrance to each building, with entrances oriented to the street. Access to each entrance is to be provided by a safe direct route, avoiding potential conflict with vehicles maneuvering on site.
4. Highly reflective materials are not acceptable for roof or wall cladding.
5. Incorporate passive solar building design principles into development, including the optimisation of sunlight access and natural ventilation and the minimisation of heat loss, to avoid the need for additional artificial heating and cooling. For example, give careful consideration to the orientation and layout of the building and the location and design of window openings to incorporate sun shading devices and to facilitate summer cooling by cross ventilation.
6. For sites in excess of 1000m², an outdoor staff recreation area is to be provided. This area:
 - a. must be a minimum of 16m² in area with a minimum dimension of 3m;
 - b. may be located within the front building setback, but not within the required 3m landscaped setback. The area may also be located within an upper floor balcony or in an enclosed courtyard;
 - c. should be designed to accommodate a table and chairs;
 - d. should be sited so that 6m² receives direct sunlight for the four hours between 10am and 2pm during mid winter;
 - e. should provide shading in summer.
7. Each unit within an industrial unit complex must provide an office space of at least 12m². This space should:
 - a. be located close to the entry of each premises;
 - b. have commercial floorspace ceiling heights;
 - c. have easy access to toilet and kitchen facilities;
 - d. attain natural daylight.
8. Where an industrial unit complex consists of more than 10 units:
 - a. building layout must allow for visual connections through and beyond the site to assist in breaking down the visual scale of the development and provide more legible site access for visitors;
 - b. consideration should be given to the use of varying architectural resolutions to further assist in breaking down visual scale and improving legibility for visitors.
9. Where development sites adjoin Woollooware Bay or an open space reservation, the site layout and building forms should allow views from within the site to the bay or foreshore.
10. Any outdoor storage area must be screened with permanent fencing with a height at least to the height of the material expected to be stored and must be adequately sealed and drained.
11. An external energy efficient lighting system is to be provided for pedestrian access and driveways.
12. Frontage works for all developments must be in accordance with the SSC Public Domain Design Manual. A minimum street tree planting rate is set at one indigenous canopy tree

that will attain a minimum mature height of 6m to be planted at maximum spacing of 7.5m.

13. For commercial premises or industrial development where high voltage power lines are not located in the site frontage, frontage works must include the bundling of local distribution power lines and other utilities and the provision of street lighting to meet the requirements of the SSC Public Domain Design Manual.
14. Where there are powerlines which are not being undergrounded or bundled, street tree planting will only be required if they can be located 2m away from the wires. Where power lines are bundled, suitable trees can be planted underneath the bundled wires.

3. Building Setbacks

Street setbacks establish the front building line. Controls over street setbacks create the proportions of the street. Setbacks contribute to the public domain by enhancing streetscape character and the continuity of street facades. Street setbacks can also be used to enhance the setting for the building. They provide for landscape areas, parking areas, entries to the ground floor of buildings and deep soil zones suitable for planting of canopy trees, particularly important for sites where overhead power lines on the street frontage make large street trees impractical.

3.1 Objectives

1. Establish the desired spatial proportions of the street with uniformity in front building lines.
2. Create opportunities for the planting of canopy trees and landscaping and space to enable existing large trees to survive and thrive.
3. Ensure that industrial developments improve the streetscape.
4. Achieve an appropriate transition between development on the fringe of Industrial zones and development in surrounding areas.
5. Provide a landscaped buffer to any adjacent residential land.
6. Provide a landscaped buffer to any waterfront public reserves.
7. Create and maintain substantial landscaping in front setbacks and maintain existing trees in landscaped setbacks in Cawarra Road zone B7 Business Park.

3.2 Controls

1. A minimum setback from the street frontage of 9m is required.
2. In the case of corner properties, the 9m setback applies to the primary street frontage, which is taken to be the narrowest street frontage.
3. Where a corner site has two or more street frontages a minimum setback of 4m applies to the secondary street frontage. However, a transitional setback greater than 4m may be required along part of a secondary frontage where a corner site adjoins a property with a 9m primary setback.
4. Nil setbacks to side and rear boundaries are permitted.
5. Despite the provisions of clause 4, development adjoining public reserves must have a minimum landscaped setback of 3m to the public reserve.
6. Despite the provisions of clause 4, development adjoining residential development must have a minimum landscaped setback of 3m from the residential development.

7. Despite the provisions of clauses 1-5, the following setbacks apply to Cawarra Road Zone B7 Business Park, being the area bounded by Cawarra Road and Meta Street and traversed by Wurrook Circuit in (refer Map 1):
 - a. An 8m building and landscaped setback from Cawarra Road, with no parking area in this setback. This landscaped area is to ensure that existing advanced trees survive and thrive, and to provide a landscaped character to Cawarra Road.
 - b. 5m building and landscaped setback from Meta Road, with no parking area in this setback.
This setback is to ensure that existing trees survive and thrive and to provide a landscaped character to Meta Street. In this 5m setback, minimal regrading should occur to allow for overland flow.
 - c. A 3m building and landscaped setback from Wurrook Circuit, with no parking area in this setback.

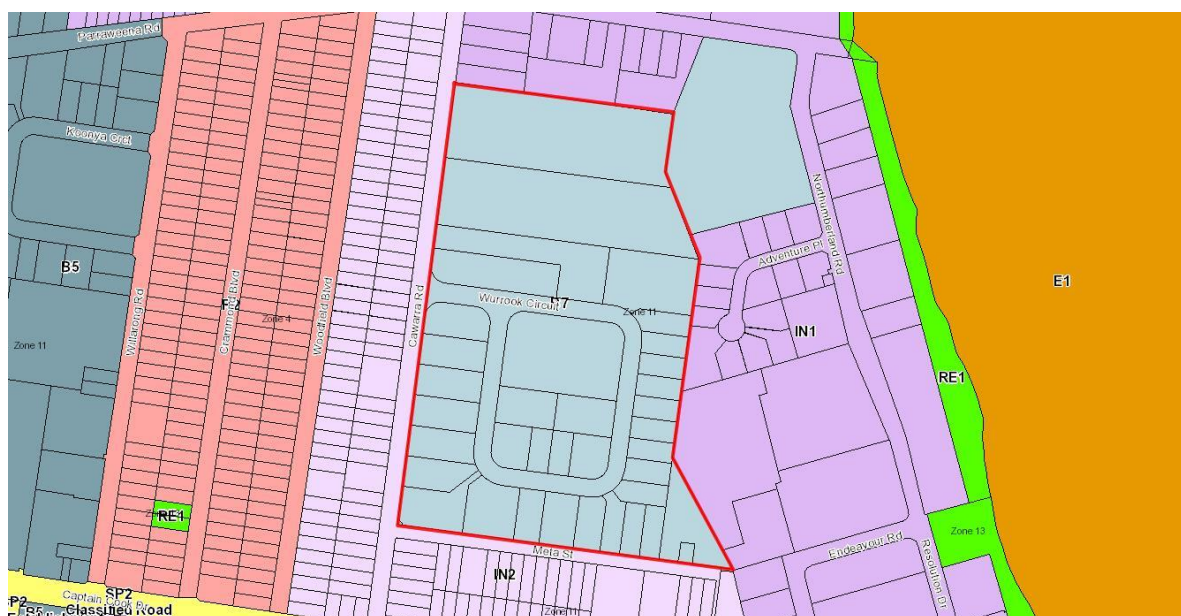

Map 1: Cawarra Road Caringbah Zone B7 Business Park

4. Daylight Access

Daylight consists of two types of light: skylight – diffuse light from the sky – and sunlight – direct beam radiation from the sun. The amount and quality of daylight changes with the time of day, season, and weather conditions. This variability contributes to pleasant environments in which to live and work.

The careful manipulation of sunlight improves amenity and enhances energy efficiency of a building. Achieving maximum daylight requires consideration of the internal layout and orientation of the development as well as the surrounding development and natural features.

4.1 Objectives

1. Locate and design buildings so that reliance on artificial light sources is minimised.
2. Design buildings to allow for potential use of solar energy.
3. Ensure the design of landscaped areas contributes to amenity with sufficient solar access.

4.2 Controls

1. Wherever possible, provide for the potential use of solar energy collectors by incorporating pitched roofs facing north.
2. The office space within each separate industrial unit should be designed to provide daylight to office areas.
3. Provide skylights wherever possible to improve energy efficiency.

5. Acoustic Privacy

Building design must take into consideration privacy and noise sources and minimise their future impact on occupants. Amenity is enhanced by privacy and a better acoustic environment. This can be achieved by carefully considering the location of the building on the site, the internal layout, the building materials used, and screening devices.

5.1 Objectives

1. To ensure development minimises the impact of industrial noise on surrounding uses.

5.2 Controls

1. All noise generating equipment must be designed to protect the acoustic amenity of residential neighbours. All such noise generating equipment must be acoustically treated and/or screened to meet the project specific noise criteria as determined by the NSW Industrial Noise Policy.

Notes:

1. In assessing noise levels at residences, the noise level is to be assessed at the most affected point on or within the residential boundary or, if this point is more than 30m from the residence, at the most affected point within 30m of the residence.
 2. In assessing noise levels at industrial premises, the noise level is to be assessed at the most-affected point on or within the property boundary.
-

5.3 Assessment Principles

Where there is conflict between a noise source (new or existing) and a sensitive receptor (proposed or existing) preference should be given to the attenuation of any noise from the source rather than at the sensitive receptor.

6. Landscaping

Good design recognises that landscape and buildings operate together as an integrated system, resulting in greater aesthetic quality and amenity for building users and the public domain. High quality landscape design protects and builds on the existing site's natural and cultural features to contribute to a development's positive relationship to its environmental context and site.

Sutherland Shire's tree cover, areas of bushland and natural beauty are valued by its residents. Landscape design in new development must recognise that existing trees, areas of habitat and natural systems must be protected and enhanced by the retention of important landscape elements, appropriate planting, bush regeneration and by minimizing urban runoff.

6.1 Objectives

1. Retain and enhance the existing tree canopy.
2. Reduce reflective heat, glare and pollution.
3. Improve biodiversity and habitat.
4. Contribute to streetscape character and the amenity of the public domain with landscaping and fencing appropriate to the desired character of the streetscape.
5. Ensure the landscaping offsets the bulk and scale of large buildings and the visual impact of paved parking areas.
6. Increase building amenity by providing landscaped outlooks and outdoor staff lunch areas.
7. Ensure that development along creeks and bays contributes positively to their ecological functioning.

6.2 Controls

1. A landscaped strip with minimum width of 3m must be provided adjacent to the front boundary (excluding the area occupied by the boundary) (see Figure 1).
2. Despite the provisions of clauses 1, for the area bounded by Cawarra Road and Meta Street and traversed by Wurook Circuit in (refer Map 1), 8 metre landscaped front setback is required from Cawarra Road, and 5 metre landscaped front setback is required from Meta Street.
3. Where site area permits, planting beds of minimum 1.5m width must be provided to side boundaries within the front setback (see Figure 1).
4. Landscaping should consist of a mix of small to large indigenous canopy trees informally spaced at 3m intervals, in conjunction with screen shrubs and ground covers. At least 50% of the trees must be capable of achieving a height of at least 6 m at maturity (see Figure 1).

5. All trees and 50% of the understorey species used in landscaping must be chosen from the species list in the Sutherland Shire Council Native Plant Selector database, except in Greenweb 'Core' and 'Support' areas, where a greater percentage is required. Potentially invasive exotic species must not be used.
6. In carparking areas, tree blisters 5.0 x 2.5m between every six (6) car spaces OR a continuous planting bed 3m wide between rows of cars must be provided (see Figure 2). The area must be capable of supporting large trees and ground covers as described above.
7. All landscaped areas are to be separated from hard paved areas by a dwarf wall or kerb to minimise damage caused by vehicles.
8. On Taren Point Road, Captain Cook Drive and the Princes Highway fencing is permitted where required for security reasons, but must be located 3m behind the front boundary.
9. Any fencing built within a front or side setback or the boundary of a public reserve is to have maximum height 1.8m, be open form and finished in black to ensure it is visually recessive.
10. All new developments will be required to install street frontage works such as street trees and/or footpath in accordance with the Public Domain Design Manual.

Note:

All indigenous tree species must be selected from Council's Native Plant Selector available on Council's website. The Native Plant Selector is a tool that recommends plants suitable for Sutherland Shire's ecosystems based on the specific address of the site locality. The tool is available online at <http://www.sutherlandshire.nsw.gov.au/Outdoors/Environment/Plants-and-Bushland/Native-Plant-Selector>

For additional guidance on landscape design and implementation refer to the Sutherland Shire Environmental Specifications - Landscape 1-5. Applicants should also refer to the Greenweb map and controls in Chapter 39 Natural Resource Management. For development application submission requirements refer to Council's DA Guide.

6.3 Assessment Principles

In assessing whether the landscaping design is high quality, Council will consider the following:

- a. Species Mix: The choice of species within the street setback has a significant impact on the streetscape presentation of a development. Required species must be suitable for the locality and make a significant contribution to the streetscape when mature. The optimal species selection should incorporate large trees to break the scale of the buildings and shade hard surface areas; large shrubs to screen onsite parking; and small plants and ground covers to provide interest at ground level and help suppress weed growth.
- b. The size, shape and orientation of spaces allocated for landscaped area:
 - i. Whether the size and shape of spaces allocated for the trees and shrubs proposed are sufficient for the species to grow to maturity. Narrow spaces can rarely support vegetation of adequate scale. Where a site's landscaped area is largely composed of very narrow spaces the design is unlikely to meet the objectives of the landscape standards despite numerical compliance.
 - ii. Whether sunlight access is sufficient to support the growth of the landscaping proposed.
 - iii. Whether trees are located such that their mature canopies will overlap.
- c. Scale of trees: Whether the scale of the trees and landscaping complements the scale of the buildings and the spaces where they are located. In employment zones, buildings will be up to 16m in height and often have large building footprints. Large trees are required so that the trees have presence in the streetscape and can partially screen the scale and bulk of buildings.
- d. Screening of Walls: The landscape design of each site needs to work closely with the architectural design solution. Where large surfaces of blank walls will be presented to the street, the landscape design solution should ensure that planting consists of layers of trees shrubs and ground covers planted informally.

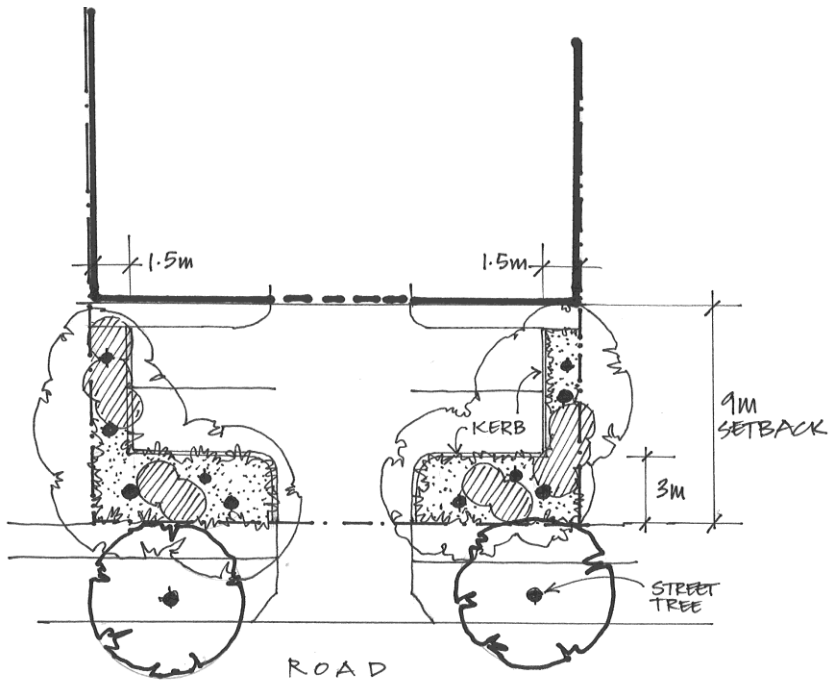

FIGURE 1

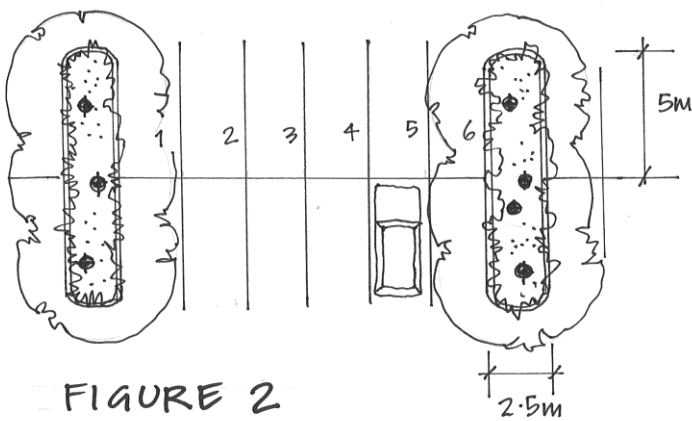
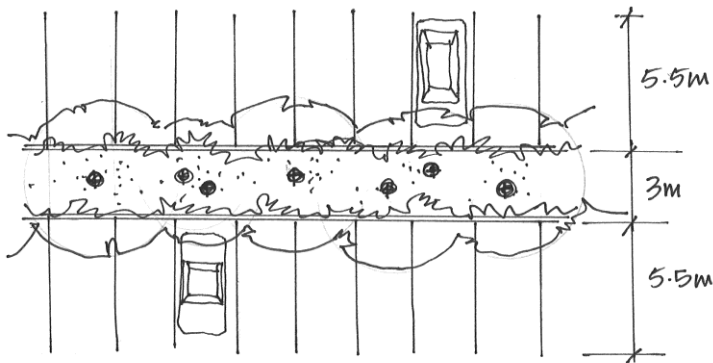

FIGURE 2

The photos below show examples of good native vegetation in industrial areas.



7. Access

The provision of an accessible built environment is both a design and legislative requirement. The provision of physical access for people with disabilities, older persons and people with temporary mobility problems is the primary purpose of incorporating accessibility requirements into development. Accessible environments provide all people with the opportunity to have equitable and barrier free movement to shops, transport, employment, recreational facilities and housing.

7.1 Objectives

1. Establish a barrier free environment for all people who live, work and visit Sutherland Shire.

7.2 Controls

1. Continuous, independent and barrier free accessways must be incorporated into the building design, including effective signage, sufficient illumination, tactile ground surface indicators and pathways with limited cross-falls, sufficient width, seating and slip-resistant floor surfaces.
2. Entrances are to enable convenient access for all.
3. Safe emergency egress is to be provided for all users.
4. Ramps, walkways, lifts and stairs are to be conveniently located and safe for all users.
5. Signage is to be provided that clearly identifies and directs access routes.
6. Building controls, services and amenities are to be located in accessible positions and be of a suitable design to allow operation by all people.

8. Safety and Security

Crime Prevention through Environmental Design (CPTED) is an integral component of high quality urban design and must be considered holistically throughout the design and development processes. The principle aim of CPTED incorporates into the design of places a consideration of how people use them, with the aim of improving personal safety and security. The desired result is to reduce the level of community fear and incidence of crime. Through appropriate design, the potential for crime can be reduced and the provision of safer urban environments can be achieved.

8.1 Objectives

1. Ensure that the design of new development carefully considers how it can minimize opportunities for future crime through passive surveillance, access control, territorial reinforcement and space management.
2. Ensure pedestrian and vehicle safety.
3. Facilitate access for emergency services.

8.2 Controls

1. Development should be in accordance with CPTED Guidelines.

Note:

The CPTD guidelines are the 'Crime prevention through environmental design' guidelines in the publication "Crime prevention and the assessment of development applications" (2001) on the Department of Planning and Infrastructure website

9. Parking

Accommodating vehicles can have a significant impact on the design of new development. The location and layout of the parking will influence the layout and design of buildings and landscaping. All development must satisfy the demand for parking that it creates within its own site.

The provision of sufficient parking must not compromise the safety of the on-street and off-street environment for vehicles, pedestrians or cyclists.

9.1 Objectives

1. Ensure all land uses and/or combinations of activities provide sufficient parking on site to satisfy the demand for parking by different vehicle types generated by the development including Traffic Generating Development.
2. Ensure appropriate on-site provision and design of parking for older people and people with limited mobility or disability, in accordance with Australian Standards.
3. Encourage greater use of more sustainable transport modes such as public transport, motor bikes, walking and cycling.

9.2 Controls

1. Car parking shall be provided in accordance with the following table:

Industrial Premises	
Industries including Light Industries	1 space per 100m ² , with a minimum of 2 spaces for each industrial unit. Any ancillary office component to an industrial development shall provide 1 space per 30m ² of gross floor area.
Commercial Premises	
Office and Business Premises	1 space per 45m ² GFA
Retail Premises	1 space per 45 m ² , GFA
Specific Uses	
Service stations	6 spaces per service bay plus 1 space per 30 m ² of convenience store plus 1 space for 8 m ² of food shop within the service station. Where no service/work bays, 1 space per 2 employees.
Vehicle and Mechanical Repair Stations	4 spaces per service bay
Vehicle sales and hire premises	1.5 spaces per 200m ²
Freight transport facilities, Passenger transport facilities, Transport depots,	1 space per commercial vehicle plus 1 space per 2 employees

Truck depots, Warehouse or distributions centres	1 space per 300 m ²
--	--------------------------------

2. Where a development is identified as Traffic Generating Development, then the parking requirement specified in the RTA Guide to Traffic Generating Development shall apply.
3. Where a proposed development is not listed in the table, or where the development proposal raises unique traffic and parking issues, or where development is identified as Traffic Generating Development, then a Traffic Report shall be completed.
4. Where a site has more than one street frontage, vehicle access should be from the lowest order road. Vehicle entry points from classified roads are only acceptable where no other access point is possible. Reciprocal rights of carriageway will be required where they can assist in achieving this outcome.
5. Bicycle parking spaces must be provided at the rate of 1 space per 10 car parking spaces for the first 200 car spaces, then 1 space per 20 parking spaces thereafter. In addition, 1 unisex shower is required per 10 employees.
6. Bicycle parking facilities are to be installed in accordance with Australian Standard AS2890.3 – Bicycle Parking Facilities (as amended), Austroad’s Guide to Traffic Engineering Practice – Part 14 Bicycles and the Austroads Bicycle Parking Facilities: Guidelines for Design and Installation (AP-R527-16).
7. Bicycle parking facilities must address the following design principles:
 - a. Accommodate all usual types of bicycles such that damage to them is minimised during storage and retrieval.
 - b. Not pose a hazard to bicycle users, pedestrians or motorists.
 - c. Be well lit, safe and secure, easy to access and use.
 - d. Cater for the different needs of residents, employees and visitors to the development.
 - e. Be located in convenient and accessible locations within the development that allow for good passive surveillance; such as near key building entrances, the lobby and the lift core.
 - f. When located within a car park, preferably be situated at street level and in a manner that provides the most direct, safe and convenient access while minimising conflict with vehicles and pedestrians.
 - g. Where a bicycle parking and storage facility cannot be located at street level, it must be located no more than one level above or below street level. Access to street level entry and exits must be direct, safe and minimise potential conflicts with vehicles.
8. Where the car parking requirement is expressed as a minimum number of spaces the development shall not exceed that minimum.
9. When the calculations for the numbers of parking spaces results in a part or fraction of a parking space of 0.5 or greater for the whole development, then the actual number shall be rounded up. For example 1.5 spaces shall be rounded up to 2 spaces for the whole development.

10. Where a development proposal contains two or more land uses, the parking requirement shall be the sum of parking required for the individual land uses.
11. Where a proposed development comprises two or more land uses with different peak parking demands, the total requirement may be reduced such that the peak demand is met at any one time, where supported by a study by a suitably qualified traffic engineer.
12. Car parking layout and vehicular access requirements and design are to be in accordance with the Australian Standards, in particular AS 2890.1-2004.
13. The location of driveways is to be determined with regard to building design and orientation, street gully pits and street trees, and is to maximize the availability of on-street parking.
14. Planting and walls adjacent to driveways must not block lines of sight for pedestrians, cyclists and vehicles.

10. Late Night Trading Premises

A late night premises is any commercial premises or community facility which may impact on the amenity and safety of a neighbourhood resulting from its operation at night. The regulation of late night trading also applies to licensed premises under the *Liquor Act 2007*.

In relation to Late Night Trading Premises controls, the area zoned B7 Business Park is a Low Activity Area.

The guidelines for Late Night Premises are in Chapter 37 - Late Night Trading.

11. Waste from Industrial, Commercial and Educational Establishments

The design of waste and recycling storage areas within a development determines the efficiency of waste handling as well as affecting user amenity and the streetscape presentation of the development.

11.1 Objectives

1. Encourage on-site waste management facilities that are integrated with the design of a development and enable source separation, reuse, and recycling.
2. Enable collection service providers efficiently collect waste and recyclables with minimum disruption and impact on the community.

11.2 Controls

1. A waste storage area is to be provided for all developments to store bins for general waste and recyclables.
2. Waste storage areas must not be within:
 - a. the front setback; or
 - b. the parking area; or
 - c. the landscaping area; or
 - d. within 3 metres of the waterway; and

must not interfere with maneuverability, efficiency and safety of site access.
3. Developments must be designed so that bins do not need to be wheeled more than 75 metres.
4. The location and design of the waste storage area must not detract from the amenity and character of the streetscape.
5. Waste and recycling facilities must be designed to prevent litter and contamination of the stormwater drainage system.
6. Bin storage and access requirements should take into consideration the future servicing requirements of the building.

Note:

Details on Waste Management Plans including a template for a typical plan are in the Sutherland Shire DA Guide and the Waste Management Information Guidelines.

Sutherland Shire Council provides a garbage and recycling collection to residential and commercial developments based on the pricing structure outlined in the Schedule of Fees and Charges for Goods and Services. The Council only has the infrastructure to services 120 litre and 240 litre mobile garbage bins. Services are available from private contractors who might use different collection vehicles and bin sizes to those used by the Council.

Garbage, recycling and garden waste bins are collected from the kerbside by Council collectors. It is the responsibility of occupants to ensure the bins are placed at the collection point, usually between the kerbside and the road reserve, by 5am on the regular service day.

7. Signage in waste storage areas must be encouraged and explain Council requirements for the separation of recyclable material and waste. Standard bin bay signage is available at cost through Council's Waste Services.
8. A tap must be provided in close proximity to the bin room/area.
9. A floor waste trap connected to the sewer shall be provided within the bin room area. Stormwater shall not be permitted to enter this floor waste trap.
10. Commercial and industrial premises require waste storage areas for 240L and/or 750L garbage bins and 240L recycling bins, having regard to the size of development and intensity of use.
11. The site and driveway must accommodate waste collection vehicles used by the garbage service provider.
12. Containment measures must be applied to all developments to prevent water pollution in the event of a spill of any liquid (other than rainwater).
13. The floors of all new industrial and commercial premises developments must either be sunken or fall to the rear and away from exit points such as doorways. The joint between the floor and wall must be sealed such that in effect a container is created to function as a secondary containment measure within the building/unit.
14. In the case of existing structures/buildings where an industrial or commercial change of use is proposed, alternative measures must be employed to achieve the objective to have in place secondary containment of liquids. These developments will need to employ measures such as containment drains and blind pits or containment humps (consider OH&S), to ensure the risk of pollution of stormwater is eliminated.
15. 50% of units in multi-unit industrial/commercial premises developments must be fitted out with drains and appropriately sized blind pits to accommodate wet processing operations to facilitate connection to the Sydney Water Sewer System under a Trade Waste Agreement. The fall of the floor of these units must be made to accommodate such an installation while still ensuring secondary containment.
16. Any development that handles hazardous, industrial or group A liquid waste must dispose of these wastes in accordance with the NSW Tracking Requirements prepared by the EPA.
17. Any development must store and handle dangerous goods in compliance with the requirements of the Occupational Health and Safety Act 2000, the Occupational Health and Safety Regulation 2001, the Explosives Act 2003, the Explosives Regulation 2005, the Radiation Control Act 1990 and the Radiation Control Regulation 2003.
18. The NSW Workcover Authority Code of Practice 2005 – 'Storage and Handling of Dangerous Goods' outlines control measures focused on physically containing the hazard and risks posed by dangerous goods and provides practical guidance to occupiers of premises on the safe storing and handling of dangerous goods.